

## **Fire Detection System Using Android-Based Microcontroller**

**Akbar Rafni Rafsan Jani <sup>1</sup>, Dwipa Handayani <sup>1,\*</sup>, Achmad Noeman <sup>1</sup>**

<sup>1</sup> Informatics, Faculty of Computer Science, Bhayangkara Jakarta Raya University; Jl.Raya Perjuangan No.81, Margamulya, Bekasi Utara, Kota Bekasi, telp/fax: 021-88955882 / 021-88955871, e-mail: [akbar.rafni14@mhs.ubharajaya.ac.id](mailto:akbar.rafni14@mhs.ubharajaya.ac.id) , [dwipa.handayani@dsn.ubharajaya.ac.id](mailto:dwipa.handayani@dsn.ubharajaya.ac.id), [achmad.noeman@dsn.ubharajaya.ac.id](mailto:achmad.noeman@dsn.ubharajaya.ac.id)

\* Correspondence Author: e-mail: [dwipa.handayani@dsn.ubharajaya.ac.id](mailto:dwipa.handayani@dsn.ubharajaya.ac.id)

*Received: 16 August 2021; Revised: 25 August 2021; Accepted: 20 September 2021; Available online: 25 September 2021*

---

### **Abstract**

The Fire Detection System can be supported by Internet of Things technology, e.g. a Microcontroller device which is used to control the related devices. In this study, android-Based fire detection system was designed in which the house owner can always monitor the condition of the house all the times and accessing the information about their house when a fire occurs until the fire suppression process is complete. Information of the house condition will be displayed on the Blynk application which is located in the kitchen area and is connected to several supporting sensors. The design of a Fire Detection System Using an Android-Based Microcontroller is divided into several stages, namely: (1) Requirement Identification; (2) Requirement Analysis;(3) Hardware Design; (4) The software design (Arduino IDE 1.8.5 and Blynk). The testing results showed that the android-based Fire Detection System Using

Microcontroller was able to provide information to residents of the house in the real-time.

**Keyword:** android, arduino IDE 1.8.5, Blynk, internet of things, microcontroller

## 1. Introduction

Information technology development gives a major impact on the development of information systems. An information system is an integration between hardware and software that is used to convert data into information (Bahagia et al, 2017). This information can be in the form of report data and public information using the web technology (Zulfan et al, 2017). The development of information systems is currently developed not only in the corporate information system, but also in various sectors of life such as disaster administration information systems, security and education so on (Satria, 2018).

The application of information technology in the security sector has been widely implemented, including in securing residential environments against fire cases. Cases of fires in residential areas often occur; Based on data about fire cases in 2018, the Indonesian Central Statistics Agency (BPS) recorded fires in residential areas 45,000 times throughout Indonesia. West Java is the province with the highest number of fire incidents in Indonesia, which is 7 thousand fire cases (BPS, 2020). Many residents have houses with a very high risk of fire, because the distance between houses and others is very narrow and in certain scenarios if a fire occurs in a company it can quickly spread to residents' homes, this is supported by the absence of a fire early warning system in a densely populated environment. Therefore, the purpose of making a fire detection system using an android-based microcontroller is urgent to add security to the fire detection system. In addition, this tool is expected to help users make this detection system more effective (Sofyan, 2019).

A previous study has been done about the automatic and dynamic microcontroller-based fire extinguishing system (Rahayu, 2017). Another research conducted by Dani Sasmoko (2017), is designing an IoT-based fire

detection system and SMS Gateway using Arduino. Also, the research conducted by Rika Sri Rizki (2017) is implementing a fire detection systems in buildings based on Programmable Logic Controller (PLC). Those other related researchs can be used to enrich the materials in this research.

The purpose of this study is to create a fire detection system using an android-based microcontroller that can inform accurately and can be monitored in real time.

## **2. Research Method**

### **2.1. Tools**

This research is focused on making a circuit system which will be connected using a connector cable with other supporting components as input, process, and output signals to then perform certain actions according to the program made in it. The main components of this circuit are Arduino Mega, with the integration of the Flame Sensor as input, Water Pump, Relay, Buzzer, LCD as program output, all of these components are included so that they become a supporting circuit in the microcontroller-based Fire Detection and Extinguishing Monitoring System that can run according to with what you want. Some of the tools and software components used in this study are discussed as follow.

a) NodeMCU and Arduino Mega 2560. They are Arduino boards which are an improvement over the previous Arduino Mega boards. Arduino Mega initially used the ATmega1280 chip and was later replaced with the ATmega2560 chip, therefore the name was changed to Arduino Mega 2560 (Andrianto, 2018), shown in Figure 1.



Source: Andrianto (2018)

Figure 1. Arduino Mega

b) Flame sensor. It works to detect infra-red and ultraviolet. Infra-Red (IR) flame detectors will respond to light emission from a flame in the infrared region of the spectrum (modulating at 5 to 30 cycles per second). I.R. flame detectors can respond to fire conditions generally in less than 50 milliseconds and are designed to detect hydrocarbon fires. Sensors typically incorporate a delayed response, selected in a time range of 3 to 30 seconds, to minimize response to non-radiative ignition sources (Figure 2).

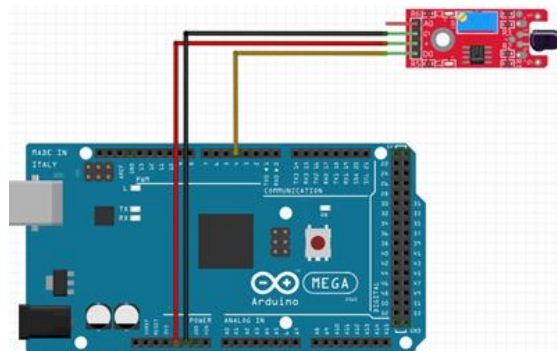

Source: (Fadhilatul, 2014)

Figure 2. Flame Sensor

c) Water pumps. Water pump is a device used to move liquids or (fluids) from one place to another through a channel (pipe) by using electric power to push water that is moved continuously. When the pump operates on the principle of making a difference on the pressure side and on the suction side, the pressure difference is generated from a mechanism that occurs in the impeller wheel which makes the suction side state not moving. This difference sucks the liquid so that it can move from one reservoir to another. The Water Pump is shown in Figure 3.

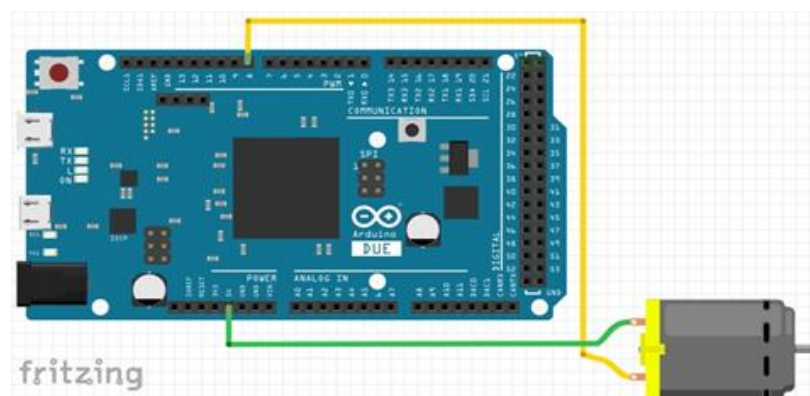
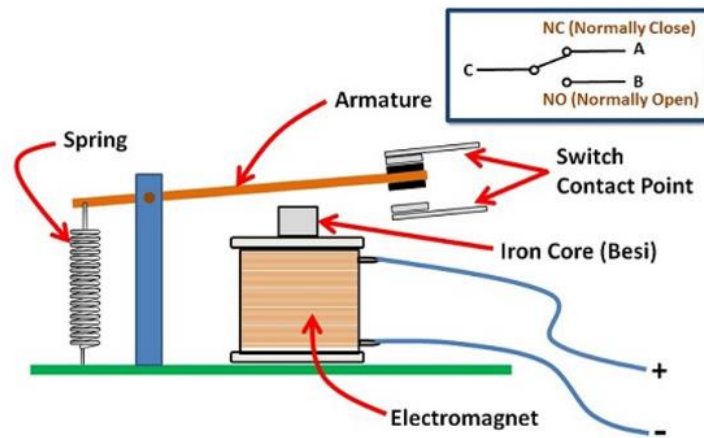

Figure 3. Water Pump

d) Relay. It works based on electromagnetic used to drive a number of contactors (switches). The current will close (off) or open (on) due to the magnetic induction effect produced by the coil when electrified. Basically the relay consists of 2 parts, namely coil and contact. The coil is a coil of wire that gets an electric current, while the contact is a kind of switch that is influenced by the presence or absence of an electric current in the coil. The relay structure is shown in Figure 4.



Source: <https://teknikelektronika.com/pengertian-relay-fungsi-relay/>

Figure 4. Relay Structure

e) LCD. It is a tool that serves to display a size or number, so that it can be seen and known through the crystal screen display. Where the use of the LCD in this temperature logger uses an LCD with 16x2 characters (2 lines of 16 characters). 16x2 LCD has 16 pin numbers, where each pin has a symbol sign and also its functions. This 16x2 LCD operates on a +5V power supply, but can also operate on a +3V power supply. (Olla, 2016). LCD is shown by figure 5

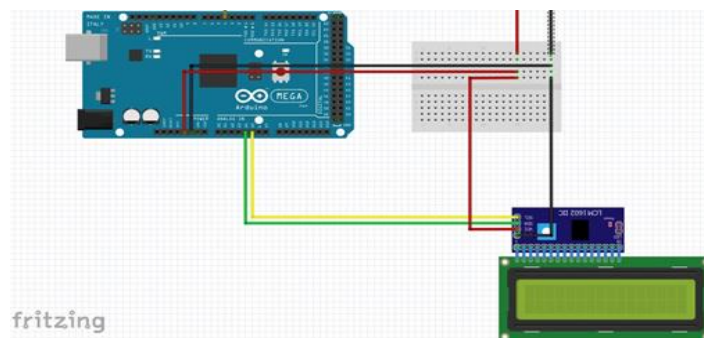
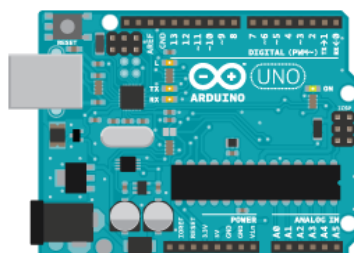

Figure 5. LCD (Liquid Crystal Display)

f) Arduino. This is an open-source single-board micro controller module, derived from the Wiring platform, designed to facilitate the use of electronics in

various fields. The hardware has an Atmel AVR processor and the software has its own programming language. The single-board micro controller on the Arduino is a form of ready-made and ready-to-use component, so there is no need for soldering to install the electronic circuit, so you can directly connect the Arduino to a computer and program it. Figure 6 shows the shape of the Arduino Uno



Source: <https://www.arduino.cc/>

Figure 6. Physical Form of Arduino Uno

g) Blynk is a platform for Mobile OS applications (iOS and Android) which aims to control Arduino, Raspberry Pi, ESP8266, WEMOS D1 modules, and similar modules via the Internet (Durani et al., 2018; Hasan & Ismaeel, 2020; Lincy & Sasikala, 2021; Noar & Kamal, 2017; Serikul et al., 2018; Siregar et al., 2020), Alif, 2021). Figure 7 shows the shape of the Blynk Logo.

## 2.2. Designing System

The plan for a fire detection device is illustrated in the block diagram shown in Figure 7.

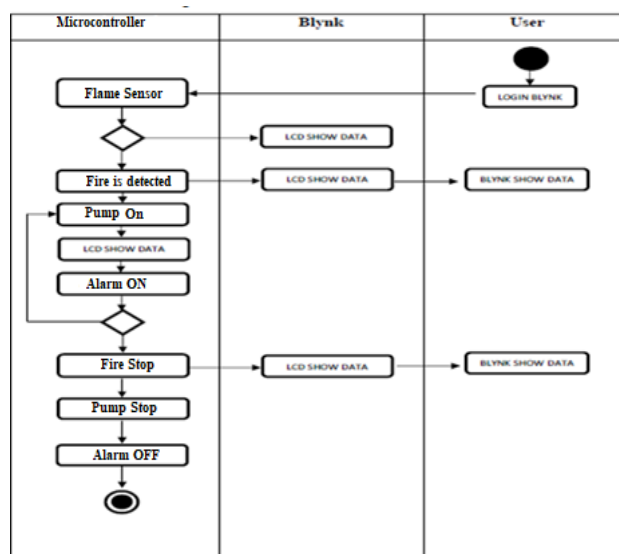

Source: Research Result

Figure 7. Activity Diagram of the System

### 2.3. Circuits Scheme

The circuit schematic shown in Figure 8 is a groove or path that is connected between each component and the component module of a fire detector

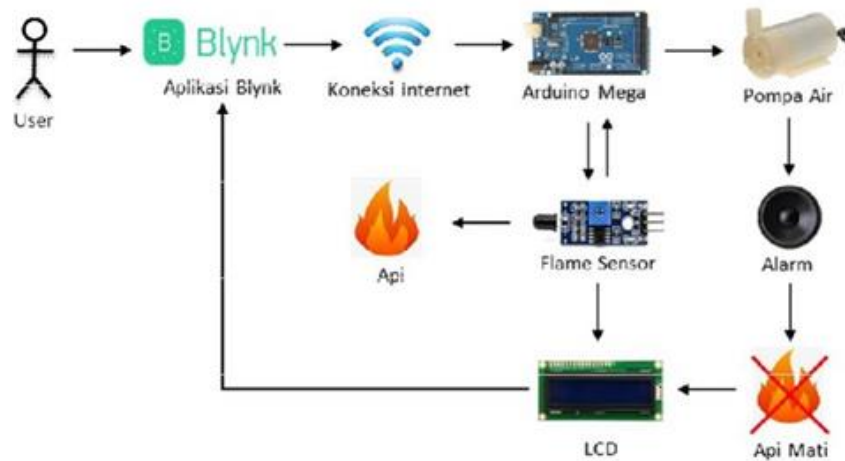

Source: Research Result

Figure 8. Circuit Schematic

The working process of the circuit schematic is as shown in Figure 8, namely: a) the user logs in to the blynk application; b) the flame sensor detects the location of a fire or not, if a fire is detected it displays information to the blynk application; c) the user turns on the water pump to extinguish the fire through the control on the blynk application; d) when the pump is activated to extinguish the fire, LED & alarm automatically turns on as information for the surrounding environment that there is a fire; e) If the fire has been extinguished the water pump automatically stops and the tool will send information to the Blynk application which will be received by the user. Table 1 is a breakdown of the components needed in this study.

Table 1. Equipment Used in System Design

Materials	Type	Number
Arduino Uno	Atmega2560	1
Flame Sensor	U.V Flame Detectors	1
Pompa Air	Pompa DC	1
Buzzer	Buzzer	1
Relay	RC522	1
LCD	LCD 16 x 2	1

Source: Research Result

### 3. Results and Analysis

#### 3.1. Testing the Components

The testing of this research is done by testing the tool or component functionally after the design is done using a Multimeter. Some of the components that were tested early are discussed as follow.

a) Flame Sensor testing. This test was carried out to determine the sensitive level of the sensor. This test is done by measuring the minimum distance of the fire until it is detected by the sensor. The author used candles to perform this test, using several sizes of candles of different sizes. The results of the tests that the author did can be seen in the following table.

Table 2. Flame Sensor Testing Result

No.	Candle Size	Distance to Fire	Hasil
1	1 cm	15 cm	Not Detected
2	3 cm	12 cm	Detected
3	4 cm	10 cm	Detected
4	6 cm	8 cm	Detected

Source: Research Result

b) Pump testing. This test was carried out to find out whether the program is in accordance with what is written in the source code and runs according to what the author planned. The results of the tests that the author did can be seen in the Table 3.

Table 3. Pump Testing Result

No	Fire	Pump	Note
1	Main Room Sensor	On	Success

Source: Research Result

c) LCD testing. This test was carried out to find out whether the program is in accordance with what is written in the source code and runs according to what the author planned. The results of the tests that the author did can be seen in the following table.

Table 4 LCD Testing Result

No	Api	LCD	Note
1	Not Detected	Smart Alarm : Save	Success
4	Main Room Sensor	Warning: Fire !	Success

Source: Research Result



d) Buzzer testing. This test was done to find out whether the program is in accordance with what is written in the source code and runs according to what the author planned. The results of the tests that the author did can be seen in the following table.

Table 5 Buzzer Testing Result

No	Fire	Alarm	Note
1	Not Detected	OFF	Success
4	Main Room Sensor	ON	Success

Source: Research Result

e) The Blynk Test. The Blynk application in the following explanation contains the implementation and performance of the Blynk application which functions as a tool for users (homeowners) as a monitoring system.

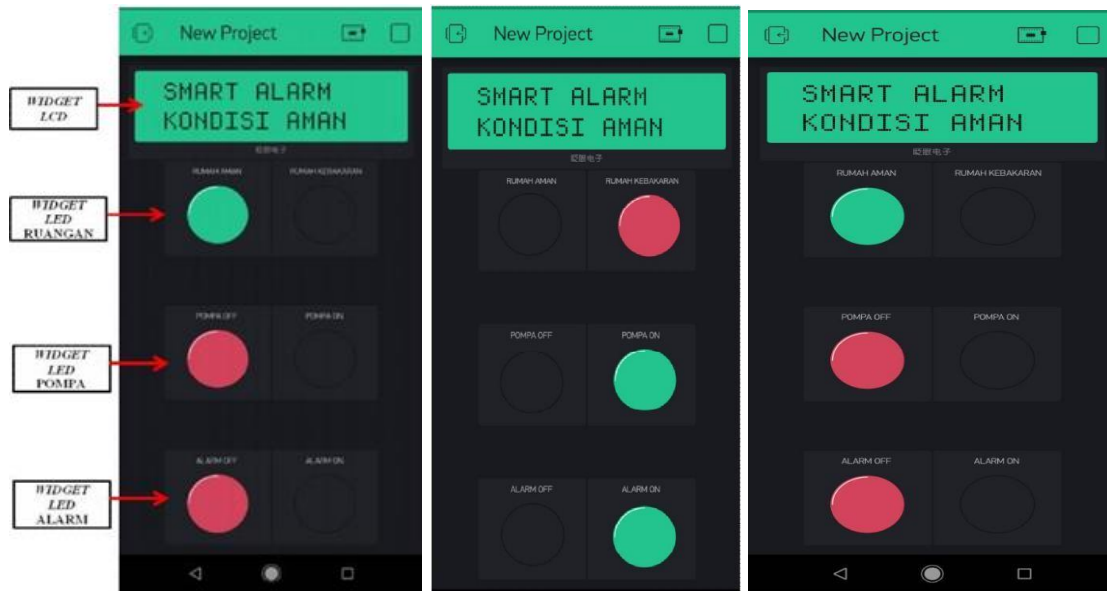

Source: Research Result

Figure 9. Blynk

### 3.2. Black Box Testing

At this stage the author used a fire detector test with the black box method. Tests are carried out on the features of the application system. This stage was carried out to ensure whether all the features in the application system can work according to what has been designed and can already work in running the application system. Testing of this application was carried out on an android smartphone and testing of the tool is carried out on candles.

Table 6. Specification of Handphone and Candle

Handphone	Candle ( Lilin )
Jenis : Smartphone	Type : Original Candle
Merk : Vivo	Distance to Fire : 1 cm, 2 cm, 3 cm, 4 cm
Type : VivoY12	
RAM: 3 GB	
Versi : Android 10(Oreo)	

Source: Research Result

Table 6 shows the information on the specifications of the cellphone and candles used in this study, and Table 7 is the result of testing the application system using black box testing.

Table 7. Hardware Testing

No.	Candle Size	Distance to Fire	Result
1.	1 cm	15 cm	Not Detected
2.	3 cm	12 cm	Detected
3.	6 cm	8 cm	Detected

Source: Research Result

The tests in Table 7 shows the good results because all functions run well. This test is carried out more than 3 times on candles with the distance from the flame to the sensor.

#### 4. Conclusion

Based on the results of the discussion, it can be concluded that the design of a fire detector using an Android-based microcontroller has been successfully tested as a solution to help people increase the security of their homes. By designing this tool, it is hoped that it can be applied more widely in the community and contribute to reducing the number of fires in residential areas.

#### Author Contributions

Akbar proposed the topic; Akbar, Dwipa and Achmad conceived models and designed the experiments; Akbar and Dwipa conceived the optimisation algorithms; Akbar, Dwipa and Achmad analysed the result.

## Conflicts of Interest

The author declare no conflict of interest.

## References

- A.S, R., & Shalahuddin, M. (2015). *Rekayasa Perangkat Lunak Terstruktur dan Berorientasi Objek*. Bandung: Informatika Bandung.
- Andrianto, H., Darmawan, A. (2018 ). *Arduino Belajar Cepat Dan Pemrograman + CD*. Jawa Timur: Informatika
- Durani, H., Sheth, M., Vaghasia, M., & Kotech, S. (2018). Smart Automated Home Application using IoT with Blynk App. 2018 Second International Conference on Inventive Communication and Computational Technologies (ICICCT), 393–397. <https://doi.org/10.1109/ICICCT.2018.8473224>
- Bahagia, Satria, D., & Ahmadian, H. (2017). Perancangan Sistem Informasi Manajemen Data Korban Bencana Berbasis Mobile Android. *Jurnal Manajemen Dan Akuntansi*, 3(2), 22–30.
- BPS. (n.d.). *Badan Pusat Statistik*. Retrieved October 1, 2021, from <https://bandungkota.bps.go.id/statictable/2021/03/25/1463/jumlah-kejadian-kebakaran-menurut-bulan-dan-penyebab-kebakaran-di-kota-bandung-2020-.html>
- Hasan, D., & Ismaeel, A. (2020). Designing ECG Monitoring Healthcare System Based on Internet of Things Blynk Application. *Journal of Applied Science and Technology Trends*, 1(3), 106–111. <https://doi.org/10.38094/jastt1336>
- Lincy, F. A., & Sasikala, T. (2021). Smart Dustbin Management Using IOT and Blynk Application. 2021 5th International Conference on Trends in Electronics and Informatics (ICOEI), 429–434. <https://doi.org/10.1109/ICOEI51242.2021.9452988>
- Noar, N. A. Z. M., & Kamal, M. M. (2017). The development of smart flood monitoring system using ultrasonic sensor with blynk applications. 2017 IEEE 4th International Conference on Smart Instrumentation, Measurement and Application (ICSIMA), 1–6.

<https://doi.org/10.1109/ICSIMA.2017.8312009>

- Satria, D., Hidayat, T., M. Aziz Hidayat, Z. (2019). Application Of SMS Gateway On Attendance Detection Systems Using RFID. *JNKTI (Jurnal Nasional Komputasi Dan Teknologi Informasi)*, 1(2), 106–113.
- Sasmoko, H., Mahendra, A. (2017). Rancang Bangun Sistem Pendeteksi Kebakaran Berbasis IOT dan SMS Gateway Menggunakan Arduino. Sekolah Tinggi Elektronika dan Komputer.
- Serikul, P., Nakpong, N., & Nakjuatong, N. (2018). Smart Farm Monitoring via the Blynk IoT Platform : Case Study: Humidity Monitoring and Data Recording. 2018 16th International Conference on ICT and Knowledge Engineering (ICT KE), 1–6. <https://doi.org/10.1109/ICTKE.2018.8612441>
- Siregar, C. A., Mulyadi, D., Biantoro, A. W., Sismoro, H., & Irawati, Y. (2020). Automation and Control System on Water Level of Reservoir based on Microcontroller and Blynk. 2020 14th International Conference on Telecommunication Systems, Services, and Applications (TSSA), 1–4. <https://doi.org/10.1109/TSSA51342.2020.9310836>
- Rahayu, N., S., Wildian. (2017). Rancang Bangun Sistem Pemadam Kebakaran Otomatis dan Dinamis Berbasis Mikrokontroler. Universitas Andalas.
- Rizki, R., S., Sara, I., D., Gapy, M. (2017). Sistem Deteksi Kebakaran Pada Gedung Berbasis Programmable Logic Controller (PLC). Universitas Syah Kuala.
- Rita, D., R. (2015). Rancang Bangun Sistem Pengendalian Listrik. *Jurnal Sistem Informasi, Teknologi Informatika dan Komputer*, Volume 7, Nomor 2.
- Zulfan, Bahagia, Ahmadian, H., & Satria, D. (2017). Sistem Informasi Data Korban Kebencanaan Berbasis Web. *Seminar Nasional II USM 2017*, 1,110–113.